



Beyondsun Green Energy Installation Manual

CONTENTS

1. Introduction	3
1.1 Rules and regulations	4
1.2 Disclaimer	4
2. General information	5
3. SAFETY PRECAUTIONS	5
3.1 Safety Warning and Operation Notice	5
3.2 General Safety	7
3.3 Handling Safety	8
3.4 Installation Safety	10
3.5 Fire Safety	10
4. Mounting	11
4.1 Location Selection and Environment	11
4.2 General Installation	12
4.3 Tilt angle selection	14
5. Installation Methods	15
5.1 MOUNTING METHOD: BOLTING	16
5.2 MOUNTING METHOD: CLAMPING	19
5.3 MOUNTING METHODS WITH SINGLE-AXIS TRACKER	25
6. Electrical Installation	27
6.1 Electrical property	27
6.2 Cables and Wiring	30
6.3 Grounding	31
7. Cleaning and Maintenance	32
7.1 Cleaning	33
7.2 Maintenance	35
8. Disclaimer	36

For Beyondsun Green Energy PV Modules

Version: BS-HANDBOOK-EN-001-F Ver: 2512

1. Introduction

This general manual provides important safety information relating to the installation, maintenance and handling of Zhejiang Beyondsun Green Energy Technology Co., Ltd.'s solar modules. Professional installer must read these guidelines carefully and strictly follow these instructions. Failure to follow these instructions may result in death, injury or property damage. The installation and handling of PV modules require professional skills and should only be performed by qualified professionals. The installers must inform end-users (consumers) the aforesaid information accordingly.

This installation manual does not entail any explicit or implicit quality warranty and does not stipulate on compensation schemes for losses, module damages or other costs caused by or related to module installation, operation, utilization and maintenance process. When there is a dispute between the parties about the root -cause of module damage, the judgment is based on the quality standards as per contract.

If customers fail to install modules as per requirements set forth in this manual, the limited warranty provided for customers will be invalid. In addition, suggestions in this manual are to improve safety of module installation, which are tested and proved through years of experience. Please provide this manual to PV system users for reference and inform the advises on operation, maintenance requirements etc.

The word “module” or “PV module” used in this manual refers to one or more Beyondsun solar modules. This manual is only valid for the module types:

TSMXXX-72H,TSMXXX-60H,TSMXXX-54H,TSMXXX-48H,TSMXXX-36H,TSMXXX-72,TSMXXX-60,TSMXXX-54,TSMXXX-48,TSMXXX-36,TSPXXX-72H,TSPXXX-60H,TSPXXX-54H,TSPXXX-48H,TSPXXX-36H,TSPXXX-72,TSPXXX-60,TSPXXX-54,TSPXXX-48,TSPXXX-36,TSHMXXX-72,TSHMXXX-60,TSHMXXX-144,TSHMXXX-120,TSHPXXX-72,TSHPXXX-60,TSHPXXX-144,TSHPXXX-120,TSHMXXX-144L,TSHMXXX-120L,TSHMXXX-144H,TSHMXXX-120H,TSHPXXX-144H,TSHPXXX-120H,TSHMXXX-144HL,TSHMXXX-120HL,TSMXXX-72HL,TSMXXX-60HL,TSMXXX-72L,TSMXXX-60L,TSHMXXX-144HW,TSHMXXX-132HW,TSHMXXX-120HW,TSHMXXX-108HW,TSHMXXX-96HW,TSHMXXX-72HW,TSHMXXX-144HV,TSHMXXX-132HV,TSHMXXX-120HV,TSHMXXX-108HV,TSHMXXX-96HV,TSHMXXX-72HV,TSHMXXX-132

HS,TSHMXXX-120HS,TSHMXXX-108HS,TSBHMXXX-132HSG,TSBHMXXX-120HSG,TSBHMXXX-108HSG,TSBHMXXX-144HVG,TSBHMXXX-132HVG,TSBHMXXX-120HVG,TSBHMXXX-108HVG,TSHNMXXX-144HR,TSHNMXXX-132HR,SHNMXXX-120HR,TSHNMXXX-108HR,TSHNMXXX-96HR,TSHNMXXX-144HR-A,TSHNMXXX-132HR-A,TSHNMXXX-120HR-A,TSHNMXXX-108HR-A,TSHNMXXX-96HR-A,TSHNMXXX-144HR-B,TSHNMXXX-132HR-B,TSHNMXXX-120HR-B,TSHNMXXX-108HR-B,TSHNMXXX-96HR-B,TSHNMXXX-156HV,TSHNMXXX-144HV,TSHNMXXX-132HV,TSHNMXXX-120HV,TSHNMXXX-108HV,TSBHMxxx-144HRG,TSBHMxxx-132HRG,TSBHMxxx-120HRG,TSBHMxxx-108HRG,TSBHMxxx-96HRG,TSBHMxxx-48HRG,TSBHMxxx-144HRG-A,TSBHMxxx-132HRG-A,TSBHMxxx-120HRG-A,TSBHMxxx-108HRG-A,TSBHMxxx-96HRG-A,TSBHMxxx-144HRG-B,TSBHMxxx-132HRG-B,TSBHMxxx-120HRG-B,TSBHMxxx-108HRG-B,TSBHMxxx-96HRG-B,TSBHMxxx-156HVG,TSBHMxxx-144HVG,TSBHMxxx-132HVG,TSBHMxxx-120HVG,TSBHMxxx-108HVG,TSBHMxxx-96HVG,TSBHMxxx-48HVG,TSBHMxxx-132HSG,SBHMxxx-120HSG,TSBHMxxx-108HSG,TSBHMxxx-96HSG,TSHNMXXX-132HT,TSHNMXXX-120HT,TSHNMXXX-108HT,TSHNMXXX-96HT,TSBHMxxx-132HTG,TSBHMxxx-120HTG,SBHMxxx-108HTG,TSBHMxxx-96HTG,TSBHMxxx-48HTG, Please retain this manual for future reference.

The protection class of the module: Class II (IEC61730:2023); (IEC61730:2016);

The application class of the module: Class A (IEC61730:2023);

Fireproof rating: Class C, in line with IEC61730-2 standard.

1.1 Rules and regulations

The mechanical and electrical installation of modules must comply with all local applicable regulations and codes, including electrical norms, including construction codes and electrical connection requirements, as well as mounting and other equipment instructions. Regulations may differ based on site-specific conditions, such as building roof installation, vehicle applications, etc. Additionally, requirements may vary depending on the installed system voltage (DC or AC). For specific terms, please contact your local authorities.

1.2 Disclaimer

Beyondsun reserves the right to change the product specifications and this installation manual without prior notice. We recommend that you refer to the Beyondsun website (www.beyondsunpv.com) for the latest product and documentation information. Beyondsun does not accept any responsibility for any loss, damage or expense arising from the installation, operation, use or maintenance of the Module, as the use of this manual and the conditions under which the Module is installed, operated, used, and maintained are beyond Beyondsun's control.

Beyondsun disclaims any liability for infringement of patents and third-party rights that may result from the use of the products. Customers are not authorized to use any patents or patent rights, express or implied, by using Beyondsun products. The information in this manual is based on Beyondsun's knowledge and experience which is believed to be reliable, including but not limited to, the product specifications above, such information and related recommendations do not constitute the terms of any warranty, express or implied.

2. General information

There are two labels on the module which contain the following information:

1. Nameplate: Each module has a nameplate, which indicates the module type, the main electrical and safety specification parameters, etc.
2. Serial Number and Bar Code Label: Each module has a unique serial number and bar code as a unique identifier, which is laminated inside the module permanently. This label can be normally found in the front side of its corners, and in the middle of the rear side of the module.

3. SAFETY PRECAUTIONS

3.1 Safety Warning and Operation Notice



DANGER OF DEATH FROM ELECTRICAL SHOCK!

PV modules can generate electricity upon exposure to light. The voltage of a single module is less than 50 VDC, but the total voltage can be dangerously high when modules are connected together in series. The following must be fully understood and obeyed when handling the PV modules to avoid risk of arcing, fire and electric shock.

- a) Carefully read through these installation instructions before installing, operating or maintaining PV system. Failure to follow these instructions may result in bodily injury or damage to property.
- b) PV systems can produce high voltage and current which could cause serious injury or even death.
- c) The installation of PV modules should only be performed by qualified personnel.
- d) Do not wear metallic jewelry when installing. Do not touch live terminals with bare hands. Use insulated tools for electrical connections.
- e) Breakage, opening the module to the exterior, of the front or rear glass can cause an electrical safety hazard, electric shock, or fire. These modules cannot be repaired and must be removed and replaced immediately.
- f) Do not install PV modules at wet conditions.
- g) Do not use damaged nor defective modules. Even damage or defective modules can produce electricity. Keep damaged or defective modules covered to avoid exposure to light.
- h) Contact with electrically active parts of a PV module such as terminals, can result in burns sparks and lethal shock whenever the PV modules are connected or not.
- i) Use appropriate safety equipment when working on any wiring.
- j) Never disassemble nor break any part of the PV module, including nameplate.
- k) Keep children and other unqualified people away from the PV system.



DANGER OF DEATH FROM ARCING!

- a) PV modules generate current under sunlight. A lethally strong arc may occur when breaking a connected module or a string of modules. Operation should be performed only by professional engineers equipped with professional tools.
- b) Never disconnect the PV module from the inverter when the inverter is still connected to the main grid, but remove the fuse from the AC side on the inverter before operation.
- c) Ensure cable and connectors are at perfect condition (no splitting, soiling, nor contamination).
- d) One should never touch the wet connectors, without using personal protective equipment or wearing insulating gloves.

3.2 General Safety

- a) All PV modules installation should be in accordance with applicable international and related local laws, codes and regulations.
- b) Artificial sunlight should not be concentrated upon the PV modules. Do not expose PV modules to sunlight concentrated with mirrors, lens or other means. Do not expose the back of the monofacial module directly to sunlight.
- c) Snow, water, or other reflective medium in surrounding environments that intensify light reflection will increase output current and power. And module voltage and power will increase under low temperature condition.
- d) The PV modules are rated as application class A. Modules rated for use in this application class may be used in systems operating at greater than 50V DC or 240W, where general contact access is anticipated. Modules qualified for safety through IEC 61730-1 and this part of IEC 61730 within this application class are considered to meet the requirements for safety class II.
- e) Under normal conditions, a photovoltaic module is likely to experience conditions that produce more current and/or voltage than reported at standard test conditions. Accordingly, the values of I_{sc} and V_{oc} marked on this module should be multiplied by a factor of 1.25 when determining component voltage ratings, conductor capacities, fuse sizes, and size of controls connected to the

PV output.

- f) Only PV modules with the same cell type and size may be connected in series.
- g) Avoid any shade on the PV module surface. Shaded cells may become hot (hotspot phenomenon) resulting in permanent damage to the module or even fire hazard.
- h) Follow safety precautions of all other components used in the PV system.
- i) Do not use the modules to replace or partly replace roofs and walls of buildings. Follow your local regulations for building integration of photovoltaic.
- j) Prohibit modules, junction boxes and connectors from coming into contact with unapproved chemicals: e.g., petrol, oil, acetone, alcohol, film strippers, potting compounds, TBP, cleaning agents, herbicides, rust inhibitors, descaling agents, etc. For more information, please contact Beyondsun technical support department.
- k) Do not use junction boxes or connectors that are contaminated (with dust, corrosion, etc.), or broken modules.
- l) To prevent arcs and electrical shocks, do not disconnect modules under load without authorization; if disconnecting the connector is needed, turn off DC and AC inverters or cut off the main switch of the converter first.
- m) PV module operation can only be stopped when they are kept from sunlight or covered by hard board (opaque material) or UV-proof materials.
- n) When connecting a battery storage system, follow the battery manufacturer's instructions for correct installation, operation, and maintenance to ensure system operation and user safety.
- o) Do not touch the module, junction box or the connectors with bare hands during installation or under sunlight, regardless if the module is connected to or disconnected from the system. The glass surface and the frame may be hot, posing a risk of burns and electric shock.
- p) Do not insert any metal object into the connector.
- q) Keep connectors dry and clean, ensuring they are in good operating condition.

3.3 Handling Safety

- a) Handle modules during deliveries and transport with care to avoid large shocks that could damage the assembly or /and cause cracks in the cell.
- b) Follow the unpacking instruction. Carry the module by at least two persons. Do not lay nor pile the PV module casually. Avoid any objects stacking or falling on the PV modules.
- c) It is recommended to use art knife or cutter to remove the packing belt and wrapping film. Violent removal is prohibited to avoid scratching the modules in the box.
- d) Once the modules are removed from the pallet, they shall be promptly installed and connected to the inverter. If they are not installed immediately, protective measures (such as adding rubber joint cover, etc.) must be taken on the connectors' head to prevent water vapour, sand, dust, insects, or other contaminants from getting inside the connector and causing poor contact or corrosion of the connector.
- e) When inspecting PV modules with AR coating technology, it will be normal to observe modules with a slight color difference at different angles.
- f) Thermal expansion and contraction effects occur on the modules. During installation, the distance between two adjacent modules must be $\geq 10\text{mm}$. If there are special requirements, please confirm with Beyondsun before installation.
- g) During the installation, as for module removal, maintenance, and any other related processes, it is recommended that the force applied between the cable and the connector, and the cable and the junction box, is not more than 60N.
- h) Do not stand nor step on the PV module. The glass may be slippery, and there is a risk of injury or electric shock if glass is broken.
- i) Please handle PV modules with care, avoiding any bump or drop.
- j) Do not expose the PV module to excessive loads on the surface of the PV module nor twist the frame, otherwise, the glass and solar cells may break.
- k) Do not draw the cable of J-box excessively during installation. The cables should be in a relaxed state after connection.
- l) Do not touch the PV module with bare hands. The frame of the PV module has sharp edges and may cause injury.
- m) Wear suitable gloves, such as leather gloves with padding in the palm and finger areas.

3.4 Installation Safety

- a) Always wear protective helmet, insulating gloves and safety shoes (with rubber soles).
- b) Due to risk of electrical shock, never perform work when PV modules are wet.
- c) Do not install PV modules at rainy, snowy or windy conditions.
- d) Ensure the connectors are fully and correctly connected. Connectors and cables should be fixed to the PV module frames, support structure or raceway to prevent movement. Keep connectors out of direct sunlight or water immersion.
- e) Do not touch the J-box and the end of the cables with bare hands during installation, regardless of whether the PV module is connected to the system or not.
- f) Do not unplug connectors if the system circuit has been connected to an operating load.
- g) Junction boxes and female-male connectors interconnections of the modules covered by this manual meet IP68 (IEC60529) requirements. However, they must be protected from prolonged direct sunlight and water immersions, to ensure long-term reliability.
- h) When installing PV modules on roofs or other structures, appropriate safety practices and safety equipment should always be used to avoid injury.
- i) Modules should be stored at the project site with additional rain protection to avoid direct open-air placement before they are installed.
- j) In order to avoid external matter such as sand or water vapour from entering and causing connection safety problems, once the modules are taken out of the box and installed, the connectors between the modules need to be connected in time, and the connectors need to be kept dry and clean during the installation process.

3.5 Fire Safety

- a) Do not install the modules anywhere close to open flames or flammable materials (hay, straw, wood, solvents, oils, etc.), or exposed to flammable and explosive gases.
- b) Please use appropriate module components to comply with local laws and regulations, as well as the building fire safety requirements before installation, such as fuses, circuit breakers and

grounding connectors, etc.

- c) Beyondsun modules fire rating is set according to IEC61730-2:2023 standard, and it can be found in the corresponding certificates. The Fire Class Rating of a module for roof mounted system shall meet local code requirements in order to achieve the specified System Fire Class Rating for a non-BIPV module. All PV systems have limitations of inclination required to maintain a specific System Fire Class Rating. For roof-top installations, it is responsibility of the designers or installers to ensure that the roof is suitable not only in terms of the structural load-bearing capacity, but also the fire resistance for the installation of the PV modules in accordance to local regulation.
- d) Make sure that the rear side of the module and the mounting surface are fully ventilated. When To facilitate ventilation and heat dissipation of the module, the minimum distance between back side of the modules and roof must be $\geq 10\text{cm}$, considering the normal physical phenomenon which the modules will be concave to varying degrees due to the gravity. The minimum clearance of any modules applied for special cases, please contact Beyondsun's technical support department.
- e) Different roof structures and installation modes will affect fireproof performance of buildings. Improper installation may lead to the risk of fire. Consult your local authority for guidelines and requirements for building or structural fire safety.

4. Mounting

4.1 Location Selection and Environment

- a) Do not install the PV module where could be flooded or immersed.
- b) Do not install the PV module in a flammable gas environment (such as gas station, storage tank etc.) nor near fire source. Please take protective measures to ensure reliable and safe installation of modules in severe environments such as heavy snow, cold and strong wind or islands close to water and salt mist or deserts.
- c) Temperature endurance range of the PV module is $-40\text{ }^{\circ}\text{C} \sim 85\text{ }^{\circ}\text{C}$, while the environmental temperature range of $-20\text{ }^{\circ}\text{C} \sim 45\text{ }^{\circ}\text{C}$ is recommended for module installation.
- d) Unless specified, the maximum bearing load of PV module is 5400Pa for front side, and 2400Pa for backside. The natural environment condition should be fully considered to not to exceed the maximum pressure. The accumulated snow should be removed in time to prevent causing any

damage to the PV modules.

- e) On the basis of IEC 61215-2016 installation requirements, when computing the corresponding maximum design load, a safety factor of 1.5 need to be considered in compliance with the local laws or regulations. (Test load = design load * 1.5 times safety factor)
- f) The PV module should not be installed in the environment of excessive salt fog, hail, sand and dust, smoke, active chemical atmosphere, acid rain etc.
- g) The PV module should be installed at least 200m away from the sea side. Corresponding measure should be adopted to avoid module corrosion and grounding failure for the distance of 200m~1000m away from sea side.
- h) The maximum altitude of module installation is 2000m.
- i) Do not install the PV module in a location where it would be immersed in water or continually exposed to water from a sprinkler or fountain, etc.
- j) When choosing a site, avoid trees, buildings or any other obstruction that could create shadows on the modules at any time throughout the year. Shading causes loss of power output and may affect the optimum performance and safety issue of the PV modules.
- k) Exposing modules to salt (i.e. marine environments) or sulfur (i.e. sulfur sources, volcanoes) incurs the risk of module corrosion.
- l) Do not expose modules and their connectors to any unauthorized chemical substances (e.g., oil, lubricant, pesticide, etc.), as modules may incur damages.
- m) Ensure that the backsheet, the front and rear glass of the module will not directly touch the mounting bracket, building structure, and environmental foreign objects (such as stones), especially under the action of external force, which will cause damage to the packaging backsheet and glass, and therefore the product warranty is invalid.

4.2 General Installation

- a) Condition of site should be fully investigated to ensure it is suitable for PV system. The installation should be designed by qualified engineer, conforming to all relevant construction/electrical laws, regulations and codes. PV installation should be approved by relevant authorities.

- b) The PV module should be mounted on supporting structures. Other components of the PV system should not have any undesirable mechanical or electrical influence on the PV module.
- c) Bearing ability of the supporting structure should be enough to sustain the modules weight and wind/snow pressure, as well as the pressure from installers and apparatus. Design of supporting structure should guarantee that there will be no effect on the modules when hot swell happens.
- d) The PV module should be firmly fixed with bolts or clamps on the supporting structure. Modules should be safely fixed to bear all expected loads, including wind and snow loads. The interval between modules should be at least 10mm
- e) Do not cause any damage of the PV modules during mounting. Do not drill holes on the frame. Otherwise, the warranty is not valid any more.
- f) Bending radius of the J-box cable should be more than 60mm.
- g) Module installation site should maintain good ventilation to facilitate the heat dispassion, which is in favor of the power generation and fire safety.
- h) For PV installation on the ground, the modules are expected to be at least one meter high from the ground to avoid soil, grass and snow covering the bottom part of the modules.
- i) For PV installation on the rooftop, the structure and bearing ability of roof must be suitable. The fastness of installation should be guaranteed to avoid the module falling off from rooftop.

**CAUTION!**

Roof structure will affect the fireproofing so it's necessary to earth ground fault circuit breaker. Unsuitable installation will bring on extra damages! When installing the module on a roof or building, do so in calm winds. Installing a module during strong winds may cause

- j) Sufficient clearance of at least 10 cm (3.94 in) between the module and the mounting surface needs to be provided to allow cooling air to circulate around the back of the module. This also allows condensation or moisture to dissipate.
- k) For the project on water surface, installation conditions should be provided in advance, so that the module manufacturer can choose the suitable materials to be in accord with the water surface installation conditions.
- l) To minimize risk in the event of an indirect lightning strike, avoid forming loops with the wiring when designing the system.

- m) After the installation of the PV modules, a 30 mm deflection for framed module is allowed.
- n) For framed modules, a minimum clearance of 6.5 mm (0.25 in) between modules is required to allow thermal expansion of the frames and modules.
- o) For optimizing the power generation of the rear side of bifacial dual-glass modules, obstacles between modules and the mounting ground should be avoided as much as possible.
- p) Constant shading conditions can affect module service lifetime, due to accelerated ageing of the encapsulation material and thermal stress on the bypass diodes.
- q) It is possible that modules installed with restricted airflow are not allowed for use in some hot locations, depending on system design parameters. Installers should assess if the system design at a specific geographic location will result in a 98th percentile module operating temperature¹ greater than 70°C, and must consider and avoid these factors in design of systems.

4.3 Tilt angle selection

The tilt angle of the PV module is measured between the surface of the PV module and a horizontal surface as shown below. The module generates maximum output power when directly facing the sun.

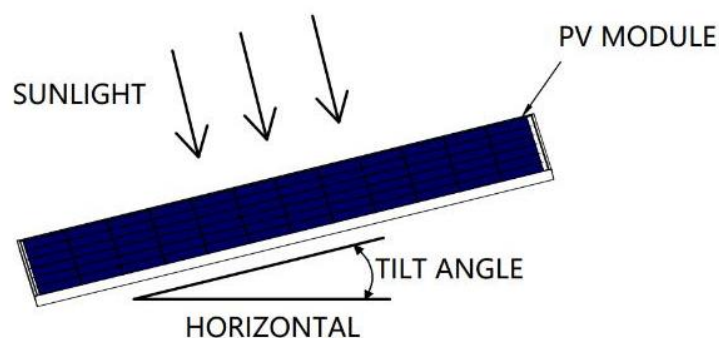

PV module tilt angle

During the installation, Beyondsun suggests the module tilt angle maintained at more than 10° to allow the rain to wash away the dust, while the module with too small tilt angle requires more frequent cleaning, which will affect the appearance and performance of the modules.

For standalone systems, the tilt angle of the modules should be selected to optimize the performance based on the season and sunlight. In general, if the module output is adequate when the irradiance is low (i.e., winter), the angle chosen should be adequate during the rest of the year. For grid-connected systems, modules should be tilted at the angle that the energy production from the modules will be maximized on an annual basis.

5. Installation Methods

Modules can usually be mounted by using the following methods: fixed installation-mounting with bolts, fixed installation-mounting with clamps and tracker installation.

All installation methods herein are only for reference, and they are based on the test results from third-party tests and Beyondsun internal tests.

Special designs, should be tested by the mounting companies, to ensure the reliability of the systems.

Beyondsun will not provide related mounting accessories.

The system installer or trained professional personnel must be responsible for the PV system's design, installation, and mechanical load calculation and system security. The design must take into consideration module' s bent/torsion, frame dimensions, fixation holes location and any other mechanic characteristic.

Before installation, the following items shall be addressed:

- a) Visually check the module for any damage.
- b) Clean the module if any dirt or residue remains.

The maximum loads that different types of modules can withstand on the front side and back side are dependent on installation methods. If there is heavy snow and strong wind on the module installation site, take special protection to meet the actual requirements.

All load values provided in this manual are maximum test load values, measured in Pa and describe as follows:

$$\text{Maximum Test Load} = 1.5 (\text{Safety factor}) \times \text{Design load}$$

The module must be mounted on the bracket according to the following installation. If there are other installation, please consult Beyondsun and obtain approval, otherwise the warranty will be invalid.

Under the mounting method of the fixed bracket as specified in this manual, the modules will be concave to varying degrees due to the gravity, which is a normal physical phenomenon and does not affect the normal use and performance of the modules. Any other external forces will cause additional sinking of the modules, so any operation of the modules should comply with this manual.

5.1 MOUNTING METHOD: BOLTING

Modules should be bolted to supporting structures through the mounting holes in the rear frame flanges only.

Each module must be securely fastened at a minimum of 4 points on two opposite sides.

Anti-corrosion bolts, elastic washers and flat washers should be used.

Suitable bolt length should be chosen based on actual module frame height. The system designer is responsible to check that the racking supplier specified bolt length comply with above requirement and will not affect installation.

In areas with heavy wind loads, additional mounting points should be used. The system designer and the installer are responsible for correctly calculating the loads and ensuring that the supporting structure meets all the applicable requirements.

Mounting method: Bolting

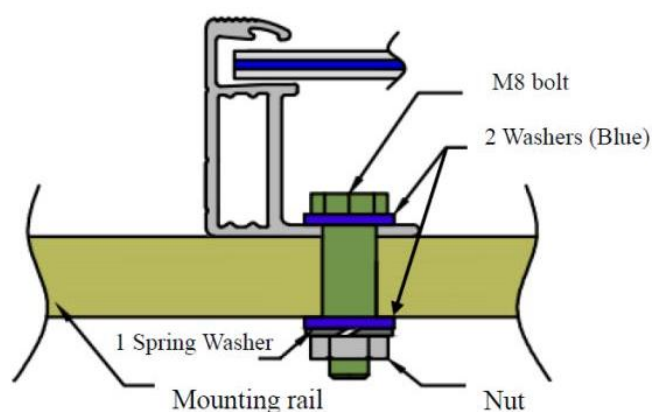
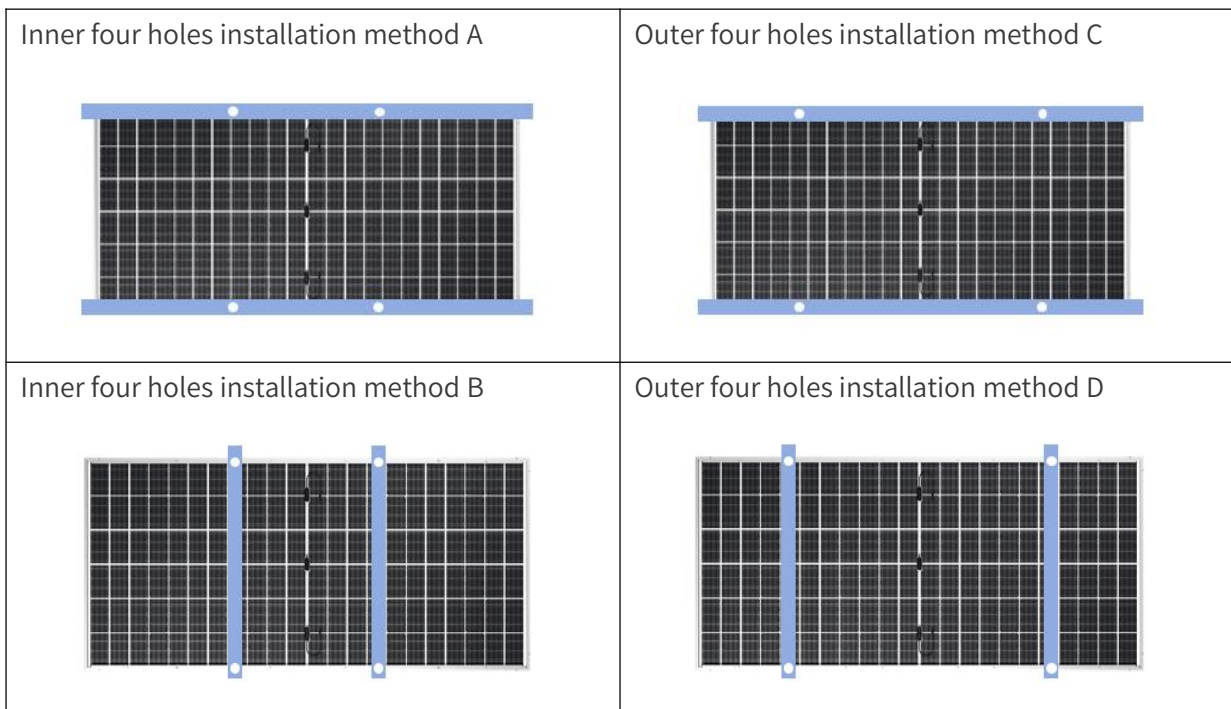

Table 1 lists different sizes of bolts for different mounting holes, along with torque recommendations. However, it is crucial to consult the installer or bracket supplier to obtain the exact torque value for your specific installation.

Mounting hole (mm)	Bolt size	Reference torque (Nm)
14 x 9	M8	16-20
10 x 7	M6	9-12

Table 1 Bolts for different mounting holes

Approved bolting methods



Module Type	Installation Method			
	Method A	Method B	Method C	Method D
TSHNM-156HV	/	+3600Pa/ -1800Pa	/	+5400Pa/ -2400Pa
TSHM-144HV,TSHM-132HV TSHM-120HV,TSHM-108HV TSHNM-144HV,TSHNM-132HV TSHNM-120HV,TSHNM-108HV	/	+3600Pa/ -1800Pa	+2800Pa/ -2400Pa	+5400Pa/ -2400Pa
TSBHM-156HVG	/	+3600Pa/ -1800Pa	/	+5400Pa/ -2400Pa
TSBHM-144HVG,TSBHM-132HVG	/	+3600Pa/ -1800Pa	+2800Pa/ -2400Pa	+5400Pa/ -2400Pa

TSBHM-120HVG,TSBHM-108HVG TSBHNM-144HVG,TSBHNM-132HVG TSBHNM-120HVG,TSBHNM-108HVG		-1800Pa	-2400Pa	-2400Pa
TSHNM-132HT,TSHNM-120HT TSHNM-108HT,TSHNM-196HT	/	+3600Pa/ -1800Pa	+2800Pa/ -2400Pa	+5400Pa/ -2400Pa
TSBHNM-132HTG,TSBHNM-120HTG TSBHNM-108HTG,TSBHNM-196HTG	/	+3600Pa/ -1800Pa	+2800Pa/ -2400Pa	+5400Pa/ -2400Pa
TSHM-132HS,TSHM-120HS TSHM-108HS	/	+3600Pa/ -1800Pa	+2800Pa/ -2400Pa	+5400Pa/ -2400Pa
TSBHM-132HSG,TSBHM-120HSG TSBHM-108HSG,TSBHNM-132HSG TSBHNM-120HSG,TSBHNM-108HSG	/	+3600Pa/ -1800Pa	+2800Pa/ -2400Pa	+5400Pa/ -2400Pa
TSHNM-144HR,TSHNM-132HR TSHNM-120HR,TSHNM-108HR TSHNM-144HR-A.TSHNM-132HR-A TSHNM-120HR-A.TSHNM-108HR-A TSHNM-144HR-B.TSHNM-132HR-B TSHNM-120HR-B.TSHNM-108HR-B	/	+3600Pa/ -1800Pa	+2800Pa/ -2400Pa	+5400Pa/ -2400Pa
TSBHNM-144HRG,TSBHNM-132HRG TSBHNM-120HRG.TSBHNM-108HRG TSBHNM-144HRG-A.TSBHNM-132HRG-A TSBHNM-120HRG-A.TSBHNM-108HRG-A TSBHNM-144HRG-B.TSBHNM-132HRG-B TSBHNM-120HRG-B.TSBHNM-108HRG-B	/	+3600Pa/ -1800Pa	+2800Pa/ -2400Pa	+5400Pa/ -2400Pa
TSP***-72,TSP***-60 TSP***-54,TSP***-48 TSP***-36,TSP***-72H TSP***-60H,TSP***-54H TSP***-48H,TSP***-36H	+5400Pa/ -2400Pa	+3600Pa/ -1800Pa	+5400Pa/ -2400Pa	+5400Pa/ -2400Pa
TSM***-72,TSM***-60 TSM***-54,TSM***-48 TSM***-36,TSM***-72H TSM***-60H,TSM***-54H	+5400Pa/ -2400Pa	+3600Pa/ -1800Pa	+5400Pa/ -2400Pa	+5400Pa/ -2400Pa

TSM***-48H,TSM***-36H				
TSHM***-144HL,TSHM***-120HL TSHM***-108HL,TSM***-96HL TSHM***-72HL,TSHM***-144HW TSHM***-120HW,TSHM***-108HW TSHM***-96HW,TSHM***-72HW	+5400Pa/ -2400Pa	+3600Pa/ -1800Pa	+5400Pa/ -2400Pa	+5400Pa/ -2400Pa
TSHM***-144H,TSHM***-120H TSHM***-108H,TSHM***-96H TSHM***72H,TSHP***-144H TSHP***-120H,TSHP***-108H TSHP***-96H,TSHP***-72H	+5400Pa/ -2400Pa	+3600Pa/ -1800Pa	+5400Pa/ -2400Pa	+5400Pa/ -2400Pa

Note: If special mounting system or special installation method is required, please verify the torque and material compatibility with the supplier of the racking system.

5.2 MOUNTING METHOD: CLAMPING

Each module must be securely fastened at a minimum of four points on two opposite sides. The clamps should be positioned symmetrically. The clamps should be positioned according to the authorized position ranges defined in table below.

Different mounting positions of the clamps determine the maximum load capacity of the module.

Depending on the local wind and snow loads, if there is a possibility of excessive load combinations:

- a) Additional clamps could be required to ensure that the module has enough load carrying capacity.
- b) Longer and/or stronger profiles/rails could be required to ensure that the module has enough load carrying capacity.

Install and tighten the module clamps to the mounting rails using the torque stated by the mounting hardware manufacturer. Tightening torques should be within 16~20 Nm for M8 (5/16" -18 Grade B7) coarse thread bolts, depending on the bolt class. For the bolt grade, the technical guideline from the fastener suppliers should be followed. Different recommendations from specific clamping hardware

suppliers should prevail.

The system designer and installer are responsible for load calculations and for proper design of support structure.

For bifacial modules, the mounting rails shall be designed to limit as much as possible the shade on module rear side cells.

Beyondsun Green Energy technology's warranty may be void in cases where improper clamps or unsuitable installation methods are found. When installing inter-modules or end-type clamps, please take the following measures into account:

1. Do not bend the module frame.
2. Do not touch or cast shadows on the front glass.
3. Do not damage the surface of the frame (to the exception of the clamps with bonding pins).
4. Under no circumstances may the frame be altered.
5. Ensure the clamps overlap the module frame by at least 5mm (0.4 in) .
6. The clamps must not be installed in contact with the front glass of the module.
7. Overlap in length by at least
 - a) 80 mm (3.15 in) when $2400 \text{ Pa} < \text{uplift load} \leq 5400 \text{ Pa}$ is required.
 - b) 40 mm (1.57 in) when $\text{uplift load} \leq 2400 \text{ Pa}$ is required.
8. Ensure the clamp thickness is at least 3 mm (0.12 in).

Clamp material should be anodized aluminum alloy or stainless steel.

Clamp positions are of crucial importance for the reliability of the installation. The clamp centerlines must only be positioned within the ranges indicated in table below, depending on the configuration and load.

For configurations where the mounting rails run parallel to the frame, precautions should be taken to ensure the bottom flange of the module frame overlaps the rail by at least 15 mm (0.59 in) for 182-cell and 210-cell PV module, and 10 mm (0.4 in) for other module series. And the shade between modules and the

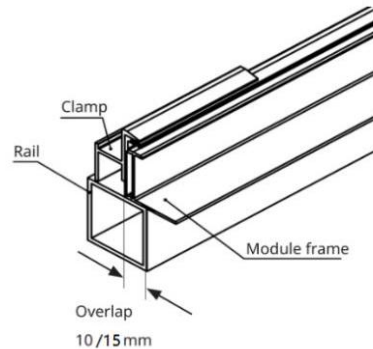

mounting ground should be avoided as much as possible.

Approved clamping methods

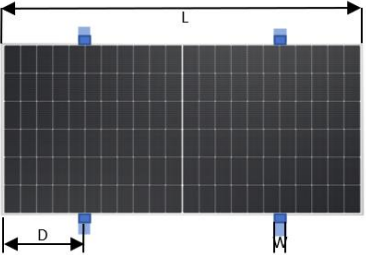
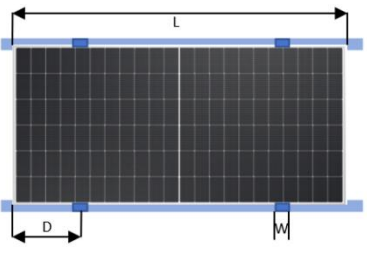
	Installation Method A			Installation Method B	
					
Module Type	Method A			Method B	
	$D=L/4 \pm 50$	$D=L/5 \sim L/4$	$D=L/5 \pm 50$	$D=L/4 \pm 50$	$D=L/5 \pm 50$
	Max Test Load (Pa)				
TSBHNM***-156HVG	/	/	+5400Pa/ -2400Pa	/	+2400Pa/ -2400Pa
TSBHNM***-144HVG	+5400Pa/ -2400Pa	+3600Pa/ -1800Pa	/	+3000Pa/ -1800Pa	/
TSBHNM***-132HVG					
TSBHNMxxx-132HTG					
TSBHNMxxx-120HTG					
TSBHNM***-144HRG					
TSBHNM***-132HRG	-A	/	/	/	/
TSBHNM***-144HRG					
TSBHNM***-132HRG					
TSBHNM***-144HRG					

-B TSBHM***-132HRG -B					
TSBHMxxx-120HVG TSBHMxxx-108HVG TSBHMxxx-108HTG TSBHMxxx-96HTG TSBHMxxx-120HRG TSBHMxxx-108HRG TSBHMxxx-120HRG -A TSBHMxxx-108HRG -A TSBHMxxx-120HRG -B TSBHMxxx-108HRG -B	/	+5400Pa/ -2400Pa	+3600Pa/ -1800Pa	/	+3000Pa/ -1800Pa
TSBHMxxx-132HSG TSBHMxxx-120HSG	/	+5400Pa/ -2400Pa	+3600Pa/ -1800Pa	/	/
TSBHMxxx-108HSG TSBHMxxx-96HSG	/	/	+5400Pa/ -2400Pa	/	+3600Pa/ -2400Pa
TSHM***-156HV	/	/	+5400Pa/ -2400Pa	/	+2400Pa/ -2400Pa
TSHM***-144HV TSHM***-132HV TSHM***-132HT TSHM***-120HT TSHM***-144HR TSHM***-132HR TSHM***-144HR-A TSHM***-132HR-A TSHM***-144HR-B TSHM***-132HR-B	/	+5400Pa/ -2400Pa	+3600Pa/ -1800Pa	+3000Pa/ -1800Pa	/
TSHMxxx-120HV TSHMxxx-108HV TSHM***-108HT TSHM***-96HT TSHMxxx-120HR	/	/	+5400Pa/ -2400Pa	/	+3000Pa/ -1800Pa

TSHNMxxx-108HR					
TSHNMxxx-120HR-A					
TSHNMxxx-108HR-A					
TSHNMxxx-120HR-B					
TSHNMxxx-108HR-B					

Module Type	Installation Method C		Installation Method D	
	Method C		Method D	
	D=130~240	D=100~240	D=130~240	D=100~240
Max Test Load (Pa)				
TSBHNM***-144HRG				
TSBHNM***-132HRG				
TSBHNM***-144HRG-A				
TSBHNM***-132HRG-A				
TSBHNM***-144HRG-B	+1600Pa/ -1000Pa	/	+800Pa/ -800Pa	/
TSBHNM***-132HRG-B				
TSBHNM***-144HVG				
TSBHNM***-132HVG				
TSBHNMxxx-132HTG				
TSBHNMxxx-120HTG				
TSBHNMxxx-120HRG				
TSBHNMxxx-108HRG				
TSBHNMxxx-120HRG-A	/	+2000Pa/ -1600Pa	/	+1600Pa/ -1200Pa
TSBHNMxxx-108HRG-A				
TSBHNMxxx-120HRG-B				

TSBHNMxxx-108HRG-B TSBHNMxxx-120HVG TSBHNMxxx-108HVG TSBHNMxxx-108HTG TSBHNMxxx-96HTG				
TSHNM***-144HR TSHNM***-132HR TSHNM***-144HR-A TSHNM***-132HR-A TSHNM***-144HR-B TSHNM***-132HR-B TSHNM***-144HV TSHNM***-132HV TSHNM***-132HT TSHNM***-120HT	+1600Pa/ -1000Pa	/	+800Pa/ -800Pa	/
TSHNMxxx-120HR TSHNMxxx-108HR TSHNMxxx-120HR-A TSHNMxxx-108HR-A TSHNMxxx-120HR-B TSHNMxxx-108HR-B TSHNMxxx-120HV TSHNMxxx-108HV TSHNM***-108HT TSHNM***-96HT	/	+2000Pa/ -1600Pa	/	+1600Pa/ -1600Pa

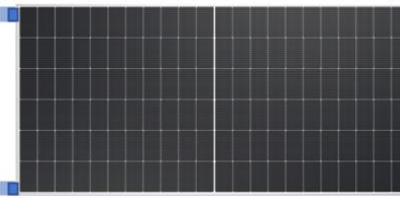
	Installation Method E	
		
Module Type	Method E	
TSBHNMxxx-108HRG TSBHNMxxx-108HRG-A TSBHNMxxx-108HRG-B	+2400Pa/ -1800Pa	

TSBHNMxxx-108HVG	
TSBHNMxxx-108HTG	
TSBHNMxxx-96HTG	
TSHNMxxx-108HR	
TSHNMxxx-108HR-A	+2400Pa/
TSHNMxxx-108HR-B	-1800Pa
TSHNMxxx-108HV	

5.3 MOUNTING METHODS WITH SINGLE-AXIS TRACKER

Beyondsun modules also have high compatibility with various mainstream tracker systems in the industry.

The bolts and clamps used in this section should follow the requirements in 5.1 and 5.2. Install and tighten the module clamps to the mounting rails using the torque stated by the mounting hardware manufacturer. M6 bolt and nut are used for this bolting method. Tightening torques should be 9-12 Nm coarse thread bolts, depending on bolt class. Different tracker systems may have large deviations. Please provide the selected tracking support supplier and product model and consult Beyondsun for details.

Tracker 1P Bolting/Clamping method:

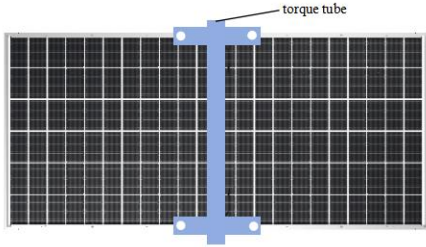
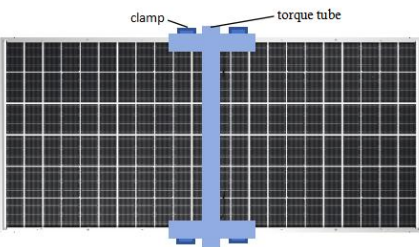
			
Module type	Load Capacities (Pa)	Load Capacities (Pa)	Load Capacities (Pa)
TSBHNMxxx-132HSG	1600-2400	TSBHNMxxx-132HSG	1600-2400
TSBHNMxxx-132HTG	1600-2400	TSBHNMxxx-132HTG	1600-2400
TSBHNMxxx-156HVG	1600-2400	TSBHNMxxx-156HVG	1600-2400
TSBHNMxxx-144HVG	1600-2400	TSBHNMxxx-144HVG	1600-2400
TSBHNMxxx-144HRG	1600-2400	TSBHNMxxx-144HRG	1600-2400
TSBHNMxxx-144HRG-A	1600-2400	TSBHNMxxx-144HRG-A	1600-2400
TSBHNMxxx-144HRG-B	1600-2400	TSBHNMxxx-144HRG-B	1600-2400
TSBHMxxx-132HSG	1600-2400	TSBHMxxx-132HSG	1600-2400
TSBHMxxx-144HVG	1600-2400	TSBHMxxx-144HVG	1600-2400

TSHNMxxx-132HT	1600-2400	TSHNMxxx-132HT	1600-2400
TSHNMxxx-156HV	1600-2400	TSHNMxxx-156HV	1600-2400
TSHNMxxx-144HV	1600-2400	TSHNMxxx-144HV	1600-2400
TSHNMxxx-144HR	1600-2400	TSHNMxxx-144HR	1600-2400
TSHNMxxx-144HR-A	1600-2400	TSHNMxxx-144HR-A	1600-2400
TSHNMxxx-144HRG-B	1600-2400	TSHNMxxx-144HRG-B	1600-2400
TSHMxxx-132HS	1600-2400	TSHMxxx-132HS	1600-2400
TSHMxxx-144HV	1600-2400	TSHMxxx-144HV	1600-2400

Tracker 1P Bolting/Clamping method:

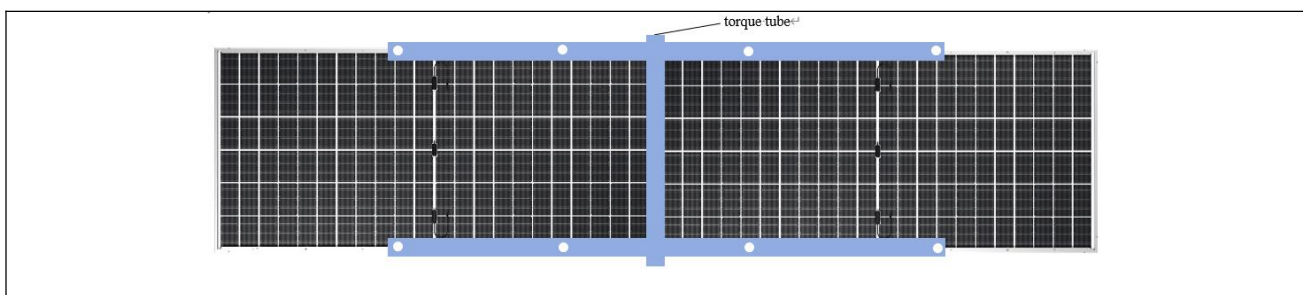

Module type	Load Capacities (Pa)
TSBHMxxx-132HSG	1200-2400
TSBHMxxx-132HTG	1200-2400
TSBHMxxx-156HVG	1200-2400
TSBHMxxx-144HVG	1200-2400
TSBHMxxx-144HRG	1200-2400
TSBHMxxx-144HRG-A	1200-2400
TSBHMxxx-144HRG-B	1200-2400
TSBHMxxx-132HSG	1200-2400
TSBHMxxx-144HVG	1200-2400
TSHNMxxx-132HT	1200-2400
TSHNMxxx-156HV	1200-2400
TSHNMxxx-144HV	1200-2400
TSHNMxxx-144HR	1200-2400
TSHNMxxx-144HR-A	1200-2400
TSHNMxxx-144HRG-B	1200-2400
TSHMxxx-132HS	1200-2400
TSHMxxx-144HV	1200-2400

For detailed installation drawings and installation method, please refer to installation manual of tracker

supplier.

6. Electrical Installation

6.1 Electrical property

Correct wiring scheme

Modules can be connected both in series or in parallel, reasonable design is required according to the system configuration. In any case, string size (quantity of modules that can be connected together, in series/parallel) must be calculated taking into consideration local regulations, chosen inverter and project location (environmental conditions, which may vary from STC). This must be done by qualified professionals.

When designing the system, avoid forming loops (to minimize risk in the event of an indirect lighting strike). Check that wiring is correct before starting up the generator. If the measured open circuit voltage (Voc) and short-circuit current (Isc) differ from the specifications, then there is a wiring fault.

- a) Use field wiring with suitable cross-sectional areas that are approved for use at the maximum short-circuit current of the PV module. Installer use only sunlight resistant cables qualified for direct current (DC) wiring in PV systems. The minimum wire size should be 4mm² and temperature rating is at -40°C to +85°C.
- b) Each module string should be equipped with fuse protector.

Cable standard	Test standard	Cable Size	Temperature Rating
	EN50618	≥4mm ²	- 40°C to +85°C

- c) Correct connection of contact plug connectors. The plug connector has its own polarity. The terminals marked with "+" and "-" represent the positive and negative terminals of the power supply. Only those terminals indicated with "+" and "-" should be connected to the load. Make sure that the connection is safe and tight. Do not connect different connectors (brand and model) together.



- d) Under normal conditions, a Module may produce more current and/or voltage than reported at standard test conditions. Accordingly, the values of ISC and VOC marked on the Module should be multiplied by a factor of 1.25 when determining component voltage ratings, current ratings, fuse sizes, and size of controls connected to the PV output.
- e) To ensure proper system operation the correct cable connection polarity (Figures A & B) should be observed when connecting the modules to each other or to a load, such as inverter, a battery etc. If modules were not connected correctly, the bypass diode could be destroyed. PV modules can be wired in series to increase voltage. A series connection is made when the wire from the positive terminal of one module is connected to the negative terminal of the next module. Figure A shows modules connected in series. PV modules can be connected in parallel to increase current (Figure B). A parallel connection is made when the wire from the positive terminal of one module is connected to the positive terminal on the next module.

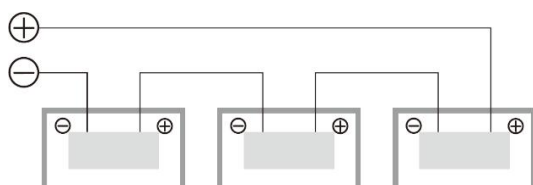

Figure A connection in series

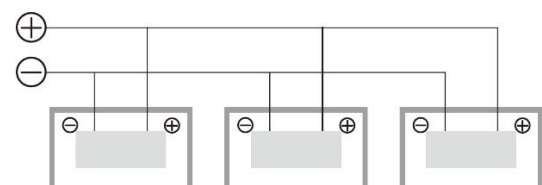

Figure B: connection in parallels

- f) The number of modules in series shall be calculated reasonably according to the system configuration and corresponding rules. The open circuit voltage under the condition of local minimum temperatures expected value cannot exceed the maximum module system voltage (according to IEC61730, the maximum system voltage of Beyondsun's module are 1000 V and 1500 V, the client may calculate according to the actual voltage of module) and the required value of the other DC electrical components.

The maximum number of the modules can be installed in a string can be calculated based on below formula:

$$N = V_{max} / V_{oc}(1 - \beta(25 - X))$$

Voc: Open circuit voltage of each module (refer to product label or data sheet)

Vmax: Maximum system voltage

B: Thermal coefficient of open circuit voltage for the module (refer to data sheet)

X: The lowest expected ambient temperature for the installation location

N: The maximum number of modules in series

- g) When modules are connected in parallel, the string current is the sum of each module individual current. In this case, the maximum recommended number of parallel connections is:

$$N \leq \text{Fuse Rating}/I_{sc} + 1$$

N: The maximum number of modules in parallel

Fuse Rating: Maximum fuse rating value in an array string (refer to product label or datasheet)

Isc: Short circuit current (refer to product label or datasheet)

- h) PV modules connected in series shall have similar current, and modules must not be connected together to create a voltage higher than the permitted system voltage stated in the label of the module. The maximum number of modules in series depends on system design and the rating of the inverter used.
- i) The maximum current rating of the module array is identified on the product nameplate or in the product specification, and the current rating also relates to the maximum reverse current that can be applied to a single module. For example, when a module is shaded, other modules connected to it will form a load causing a current loop. Depending on the maximum fuse current rating of the modules and the local electrical installation standards, the connection of parallel strings of modules needs to be fitted with suitable fuse protection for circuit protection reasons.
- j) The cross-sectional area and cable connector capacity must satisfy the maximum short-circuit of the PV system (for a single module, it is recommended that the cross-sectional area of cables be 4mm^2 and certified to IEC 62930 type 131), otherwise cables and connectors will become overheating for large current. Please pay attention that the temperature limit of cables is 90°C .
- k) Beyondsun modules junction boxes contain factory-installed bypass diodes. These diodes are connected in parallel with each cell string to allow the current flow to the next cell array in case

there are hot spots or partial shadows in any of the other cells' string. This will avoid performance and heating losses.

- If modules are incorrectly connected to each other, the bypass diodes, cables or junction boxes may be damaged.
- Keep in mind that bypass diode is not an over-current protection.
- Please do not try to open module junction boxes by yourself.
- Bypass diodes from different manufacturers should not be mated together. If such a replacement is needed, please contact Beyondsun.

l) For floating projects, please contact local technical support.



CAUTION!

Connectors provided by different suppliers will not mutual match up. Different connectors provided by one supplier will not match up either. Only one type of the same connector from one supplier shall be used to ensure the reliability of electrical connection. The plug connector should not receive outer stress. Otherwise, it is only used to connect the circuit!

6.2 Cables and Wiring

- a) The wiring and cable management should be designed, reviewed and approved by the EPC contractor, especially for assemblies using tracking brackets. The required cable lengths should be checked in advance, to ensure good functionality and proper installation.
- b) The wiring should be checked for correctness before starting the system. If the measured open-circuit voltage (V_{oc}) and short-circuit current (I_{sc}) do not match the specifications provided, there may be a wiring fault.
- c) Each string should be left open-circuit until the system is connected to the grid after the modules have been installed. Appropriate protection is required to avoid the ingress of water vapour and dust.
- d) When wiring modules, always keep in mind the minimum bend radius (see the figure below). This minimum bend radius is the permissible curvature the cable can be bent around. Depending on the type of cable, a specific coefficient (Cable multiplier), must be applied. For our DC cables this

parameter is 4 as default.

$$\text{Minimum Bend Radius (R)} = \text{Cable Outer Diameter (d)} \cdot \text{Cable Multiplier}$$

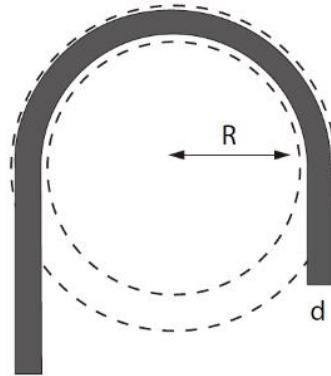



Figure Minimum Bend Radius

- e) Beyondsun does not guarantee the safety of products and technical parameters consistency if the connecting heads and tools used are not officially specified by Beyondsun or are not installed according to the official requirements.
- f) Before the commissioning and operation of the power station, verify the electrical connection of modules and strings, ensuring all connections and polarities are correct, and the open circuit voltage meets the requirements of the acceptance criteria. Incorrect connections may lead to electric arc and electric shock. Please always check that all electric connections are reliable and that all connectors are fully locked.
- g) Connect the conductor from the PV arrays to the combiner box in accordance with the design and local codes and standards.

6.3 Grounding

- a) For safety reasons and to protect modules from lightning and electrostatic damage, the module frame must be grounded. The grounding design and the materials used should be in accordance with local national, regional or international regulations, codes, laws and standards, and the grounding connection should be carried out by qualified electricians.
- b) Grounding PV modules is necessary to reduce or eliminate shock and fire hazards. The installer of a PV system is responsible for grounding each module frame.
- c) The grounding device must penetrate the anodic oxide film of the component frame and make full contact with the interior of the aluminum alloy, and the grounding conductor must be connected

to earth ground through a suitable grounding electrode.

- d) There are grounding holes with a diameter of 4mm on the long side of the back frame of the module, by the edge part. The grounding hole on the frame is marked with typical grounding symbol () according to IEC 61730-1:2023 standard. These holes can only be used for grounding with bolts, so cannot be used for module installation. The bolts should be tightened when grounding is installed. The frame of the module must not be punched with additional holes and no damage should be done to the module frame or the grounding wire.
- e) Grounding devices and materials must be provided by qualified manufacturers. Bolts, nuts and washers shall be of a size to match the grounding hole and made of stainless steel, and grounding wires shall be made of copper core wires with a size of AWG 6-12 (4-14 mm²) and 90°C, and shall be in accordance with relevant local national, regional or international regulations, laws and standards.
- f) PV module frame is made of anodized aluminum. Corrosion can occur if PV module is subject to a salt-mist environment and is in contact with another type of metal (electrolytic corrosion). If condition permits, PVC washers may be placed between PV module frame and support structure to prevent this type of corrosion. All bolts, nuts, washers for grounding should be made of stainless steel, unless otherwise specified.
- g) Beyondsun allows other grounding methods. However, the following requirements need to be met:
 - It is the sole responsibility of the Installer to select the correct grounding system.
 - Said grounding system must comply with the corresponding electrical codes.
 - Beyondsun modules must be properly grounded.
 - The chosen grounding methodology does not affect the Beyondsun Power and Product Warranty in any way.
 - Beyondsun is not responsible for any failure or defect caused by the selected grounding methodology.

7. Cleaning and Maintenance

7.1 Cleaning

A buildup of dust or dirt on the module front face will result in a decreased energy output. Clean the module preferably once per month, more frequently in dusty conditions, using soft cloth dry or damp. Appropriate maintenance measures shall be taken to keep the assembly free of snow, guano, seeds, pollen, leaves, branches, dust and stains, etc.

- a) Water with high mineral content may leave deposits on the glass surface and is not recommended. It is recommended to use neutral water of the PH value ranging from 6.5 to 8 to clean the glass, so as not to cause damage to the glass coating layer.
- b) Never use abrasive material under any circumstances.
- c) In order to reduce the potential for electrical and thermal shock, Beyondsun recommends to clean PV modules during early morning or late afternoon hours when solar irradiation is low and the modules are cooler, especially in regions with hot temperatures.
- d) Do not change the PV components optionally (diode, junction box, plug connectors). Never attempt to clean PV module with broken glass or other signs of exposed wiring, as this presents a shock hazard.
- e) In most conditions, the normal rainwater can keep the module glass clean. Clean the glass surfaces with wet soft sponge or cloth if necessary. Use mild non-abrasive cleaning agent to remove stubborn dirt. If the module installation Angle with the ground is 0° , it required relatively frequent cleaning frequency. In general, if installation Angle is 15° , the module's self-cleaning ability is better than 0° .
- f) Do not use high pressure water spray nor chemicals to clean the PV modules. For the environment with extreme climate, please contact Beyondsun after-sales department for specific requirement if needed.
- g) When cleaning PV modules, do NOT step on the modules; do NOT spray water on the backside of the module or the cables; do NOT clean the backside of the modules; keep the connectors clean and dry; prevent fire and electrical shock from occurring; do NOT use as steam cleaner.
- h) Modules can work effectively without cleaning, but removing dust from the glass surface can increase output power. Use a wet sponge or cloth to clean the surface of the glass. Wear rubber gloves for maintenance.

- i) If the back surface of the module need to be cleaned, avoid the use of any sharp projects that might damage the penetrating the substrate material. For single-side module, backsheet cleaning is not necessary; for dual-glass module, cleaning the module backside regularly when necessary. Please wear insulated gloves and pay special attention to the cables and electrical connections during the backside cleaning.
- j) When cleaning the modules, make sure that the temperature difference between the water and the module is in the range of -5°C to 10°C.
- k) Use a dry or wet, soft and clean cloth, sponge, or soft bristled brush to wipe the photovoltaic module. Please make sure that the cleaning tools do not wear out glass, EPDM, silicon, aluminum alloys or steel.
- l) If there is greasy dirt or other substances which are difficult to clean, conventional household glass cleaning agents can be used. Pay attention not to use alkaline and strong acidic solvents, including hydrofluoric acid, alkali, acetone.
- m) Do not clean the modules during the hottest time of the day to avoid thermal stress on the modules.
- n) Wear suitable protective clothing (clothes, insulating gloves, etc.) when cleaning the modules.
- o) Do not clean modules under the weather conditions of wind more than 4 class (in Beaufort scale), heavy rain or heavy snow.
- p) When cleaning the modules, it is forbidden to step on the modules, forbidden the injection of water to the backside of the modules or cables. Please ensure that the connectors are clean and dry to prevent electric shock and fire hazards.
- q) Do not use steam cleaner.

Method A: Compressed water

Requirement for water quality:

- PH: 6~8.
- Water hardness-Calcium carbonate concentration: ≤ 600 mg/L.
- Recommend to use soft water to wash.
- The recommended maximum water pressure is 4 MPa (40 bar).

Method B: Compressed Air

Beyondsun recommends using this method to clean the soft dirt (like dust) on modules. This technique can be applied as long as the method is efficient enough to clean the modules considering the on-site conditions.

Method C: Wet cleaning

If excessive soiling is present on the module surface, a non-conductive brush, sponge, or other mild agitating method may be used with caution.

Please make sure that any brushes or agitating tools are constructed with non-conductive materials to minimize risk of electric shock and that they are not abrasive to the glass or the aluminum frame.

If grease is present, an environmentally friendly cleaning agent may be used with caution.

Method D: Cleaning robot

If a cleaning robot is used for dry cleaning, the brush material is required to be soft plastic material, and the glass surface and aluminum alloy frame of the module will not be scratched during the cleaning process and after cleaning. The weight of the cleaning robot should not be too large. If the cleaning robot is improperly used, and the resulting module damage and power attenuation are not covered by Beyondsun's warranty.

7.2 Maintenance

- a) All fastenings should be kept tight and secured free of corrosion. It is recommended to perform a preventive inspection every six months without changing the components of the module. If electrical or mechanical properties are required for inspection or maintenance, qualified professionals should be advised to avoid any electric shock or loss of life.
- b) Check the sealing gels of the junction box for any damage and examine the modules for signs of deterioration.
- c) Inspect for loose or corroded electrical interfaces, loose connections between supports and components, connections between cables, connectors, and grounding. Check the grounding resistivity routinely.

- d) Replacement modules must be of same type. Do NOT touch live parts of cables and connectors. Use appropriate safety equipment (insulated tools, insulating gloves, etc.) when handling modules.
- e) All fastenings should be kept tight and secured free of corrosion. All cable connections should be secure, tight, clean and free of corrosion. Cables should be kept intact.
- f) PV module should not be discarded casually, but should be recycled by professional organization.
- g) Trim any vegetation which may shade the solar array, thus impacting performance.

8. Disclaimer

- a) Beyondsun Green Energy gives no warranty of any kind whatsoever, either explicitly or implicitly, with respect to the information contained herein.
- b) Beyondsun Green Energy have rights of modifying manual, PV products, specifications or the rights of the product information, without prior notice.
- c) This manual information based on reliable our knowledge and experience, including product specifications of the information and advice does not constitute any guarantee.
- d) Do not dispose of electrical appliances as unsorted municipal waste, use separate collection facilities. Contact your local government for information regarding the collection systems available. If electrical appliances are disposed of in landfills or dumps, hazardous substances can leak into the groundwater and get into the food chain, damaging your health and well-being. When replacing old appliances with new ones, the retailer is legally obligated to take back your old appliance for disposals at least free of charge.

Zhejiang Beyondsun Green Energy Technology Co., Ltd.

Add: No.888 Zhili Section of G318 Zhili Town, Huzhou City, Zhejiang Province, China

E-mail: info@beyondsunpv.com

Web: www.beyondsunpv.com